

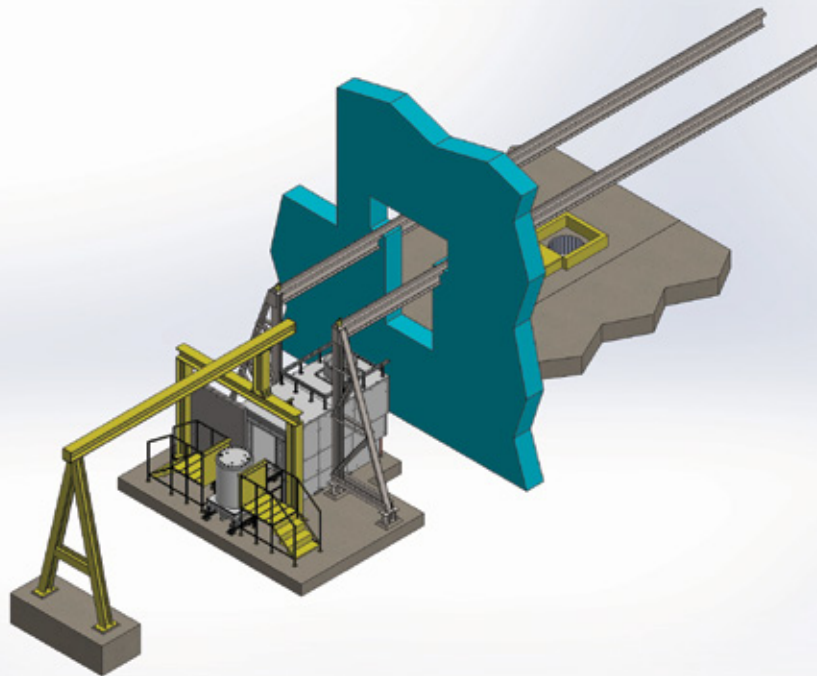

CASE STUDY

PROJECT TITLE: **BERKELEY CHUTE SILO PROJECT –
IMPORT/EXPORT FACILITY**
CLIENT: **MAGNOX**



AIMS AND OBJECTIVES



The project was to design, manufacture, factory test, install and commission two pieces of plant for the Chute Silo Project at Berkeley; a Shielded Transfer Flask & an Import/Export Facility. This case study describes the import/export facility.

ABOUT THE CLIENT



Magnox Ltd is the management and operations contractor responsible for safely managing 12 nuclear sites and one hydroelectric plant in the UK, working for the sites' owner, the Nuclear Decommissioning Authority (NDA).

Magnox is responsible for managing the sites through their lifecycles, overseeing all aspects of defuelling and decommissioning.

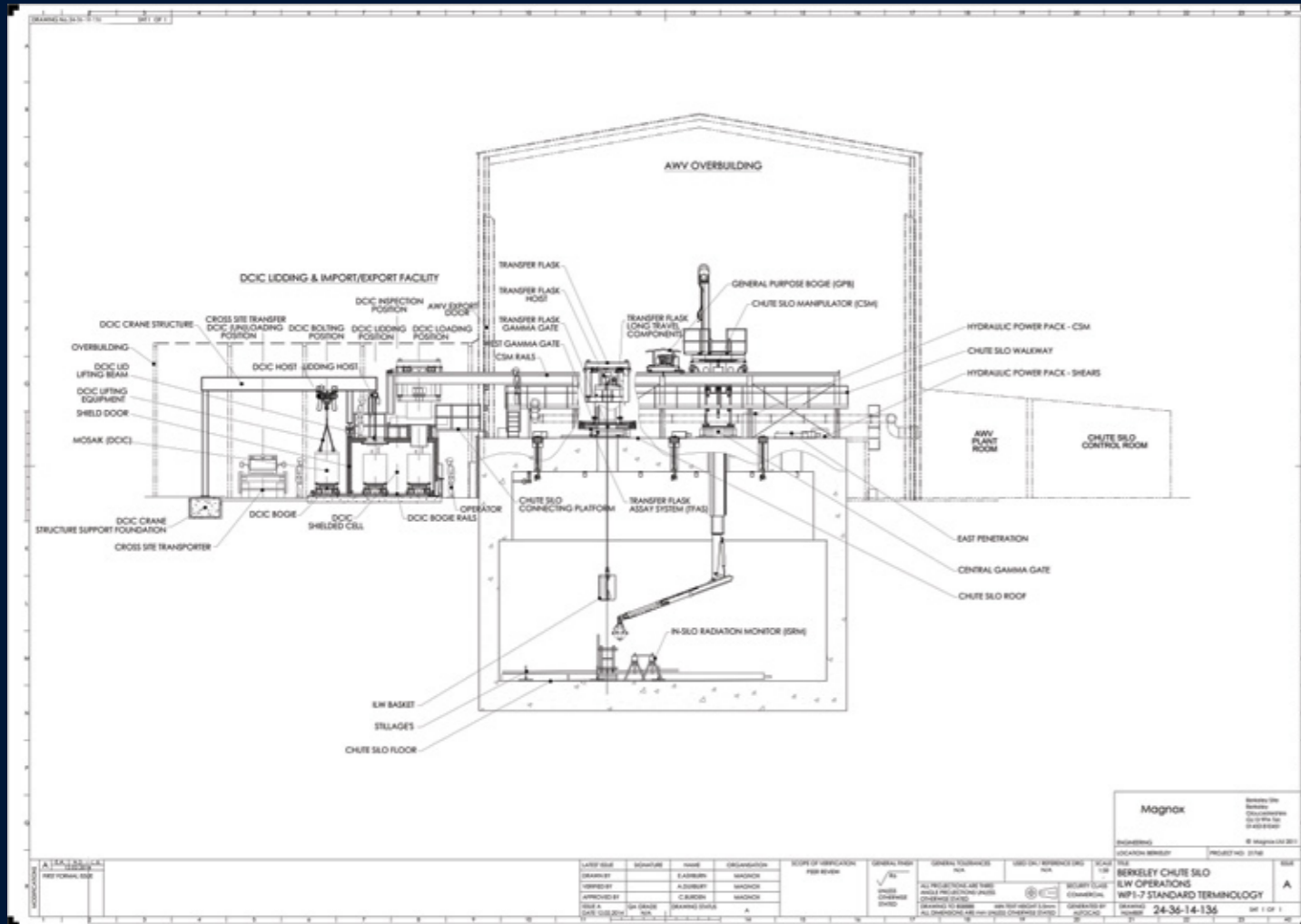

PROJECT OVERVIEW

The Chute Silo ILW project, was set up by Magnox, to retrieve waste in the form of irradiated control rods and charge chutes, from a storage silo on the Berkeley nuclear site.

The project involved carrying out in-silo, size reduction of the waste, retrieval from the silo and transfer of the waste to a shielded container for export to an on-site storage facility.

A scheme design was produced for the process and equipment to carry out the Chute Silo Project.

This equipment comprised:

- Transfer Flask to transfer the waste retrieved from the silo to an external facility/module.
- Import/Export facility to receive waste packages from the Shielded Transfer Flask and facilitate the waste packages being loaded into Ductile Cast Iron Containers (DCIC).

Health and safety was the primary objective but during the design a high emphasis was placed on the duty and fit for purpose since it was estimated that only 35 transfers were required between the chute silo and the import/export facility.

IMPORT/EXPORT FACILITY

The Import/Export facility is, in effect, a small, shielded cell which allows DCIC to be loaded with waste baskets from the Transfer Flask. It includes de-lidding equipment for the DCIC and a position for DCIC inspection and un-bolting. The DCIC moves between stations on a bogie, running on rails. A hoist on an overhead runway beam, is used to transfer the DCIC from the cross-site transporter onto the bogie. The Import/Export facility is located outside the Active Waste Vault facility building and interfaces with the external portion of the CSM rail structure, on which the Transfer Flask runs.

SHIELDED CELL DESIGN

During the bid, Aquila designed the complete cell using a frame and steel slab construction. This eliminated weld preparations, welder qualification, non destructive testing and assembly on site using special lifting equipment.

TROLLEY, RAIL AND TRANSFER SYSTEM

The Aquila design, proposed the use of standard COTS rails and wheel assemblies. This resulted in a low profile, simple, fabricated trolley. We employed COTS linear chain drive to move the drum trolley back and forth. This was manually operated.

DRUM LID REMOVAL

Employing a more flexible drum lid lifting solution, also allowed the design to offer radiological shielding within the shielded cell. Our solution saved significant design, precision manufacturing, works assembly and testing.

HOIST RAILS

The Aquila design, integrated both rail functions saving design, manufacture and most importantly, installation costs.

ACCESS PLATFORM

By adopting a standard suite of access ladders and platforms used to access the top of the shielded cell, we were able to again reduce the price for special solutions.

PROGRAMME, CONTINGENCY AND PROJECT MANAGEMENT

As with the Transfer flask, by adopting a pragmatic approach, we were also able to reduce the original project programme and contingency, significantly.

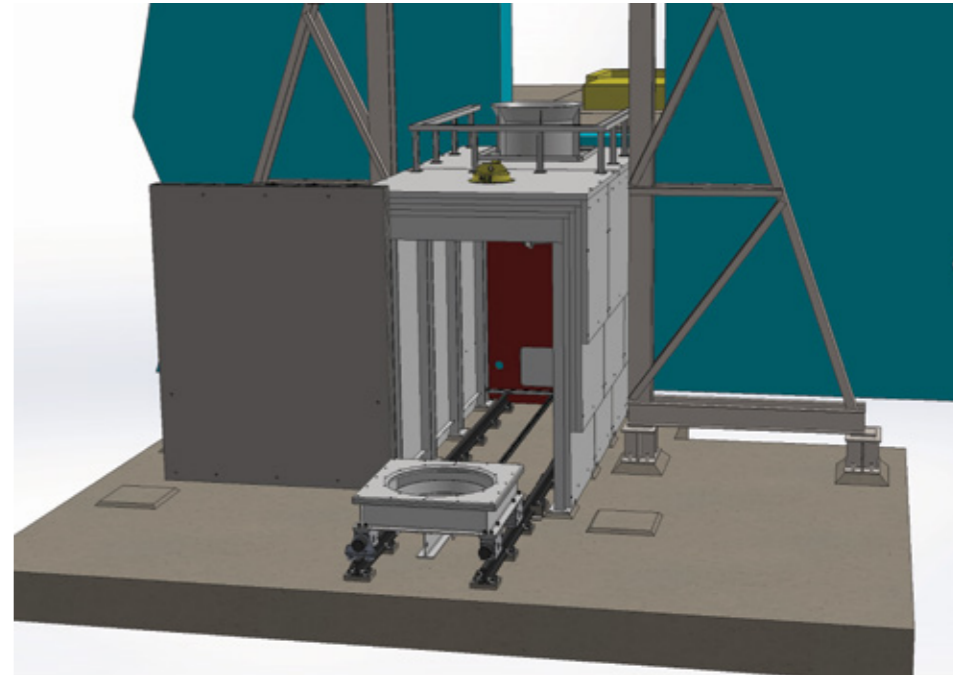
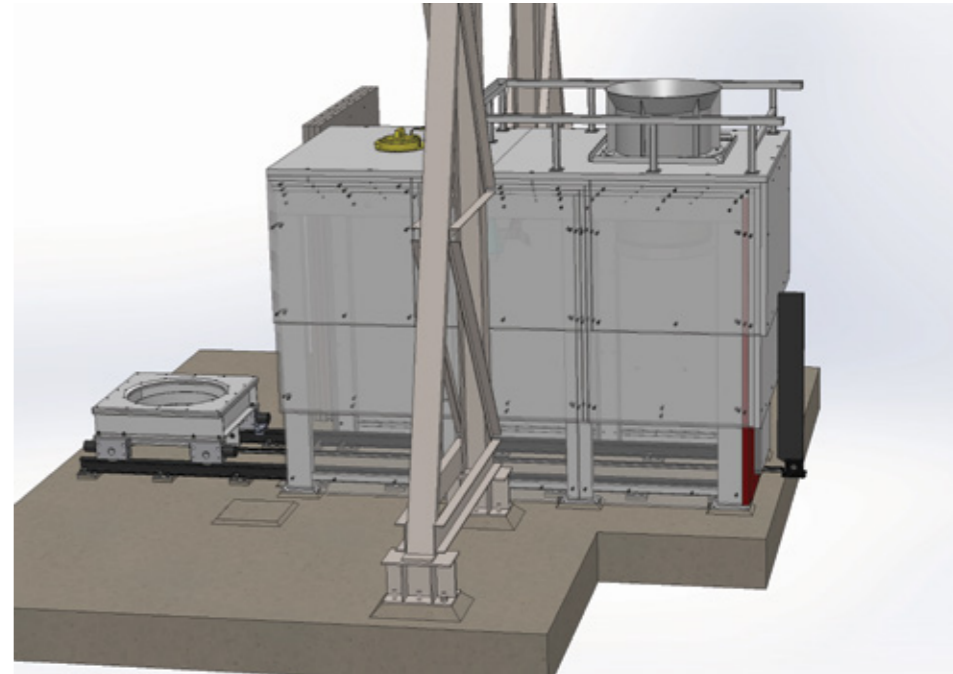



Magnox and Aquila Chute/Silo team after site acceptance

SUMMARY

During the tender process, Aquila designed a system in 3D solid works to meet the functional specification. This not only allowed us to de-risk the design from a functional aspect but also enabled accurate estimating to fix the price.

“ Aquila offer was a breath of fresh air, simple, pragmatic and very competitive. Magnox are tasked with undertaking decommissioning at pace and at good value. Working with Aquila from the Tier 3 arena, goes a long way towards helping us achieve this. ”

Quote from Chris Burden,
Project Manager Chute & Silo Magnox



T: +44 (0) 1962 717 000

E: info@aquilaeurope.eu

[linkedin.com/company/2439808](https://www.linkedin.com/company/2439808)

twitter.com/aquilanuclear1

Aquila House, Hazeley Enterprise Park,
Hazeley Road, Twyford, Hampshire
SO21 1QA, United Kingdom

ACCREDITATIONS



Aquila Nuclear Engineering is part of
the Calder Group

Pragmatic, cost effective solutions, always